

TMC2340A

Digital Synthesizer

Dual 16 Bit, 50 Msps

Features

- User-configurable phase accumulator for waveform synthesis, frequency modulation or phase modulation
- Amplitude input for amplitude modulation and gain adjustment
- Guaranteed 50 Msps pipelined data throughput rate
- 15-bit magnitude, 32-bit phase data input precision
- 16-bit offset binary or 15-bit unsigned magnitude output data format
- Input register clock enables simplify interfacing
- Low power consumption CMOS process
- Single +5V power supply
- Available in a 120-pin plastic pin grid array package (PPGA) and 120-pin metric quad flat pack (MQFP)

Applications

- Digital waveform synthesis, including quadrature functions
- Digital modulation and demodulation

Description

The TMC2340A performs waveform synthesis, modulation, and demodulation. When presented with a TTL clock signal and user-selected 15-bit amplitude and 32-bit phase increment values, the TMC2340A automatically generates quadrature matched pairs of 16-bit sine and cosine waves in DAC-compatible 16-bit offset binary format. If desired, these waveforms are easily phase or frequency-modulated on-chip, and the amplitude input facilitates gain adjustment or amplitude modulation. Digital output frequencies are restricted only by the Nyquist limit of clock rate/2, with frequency resolution of 0.012 Hz at the guaranteed maximum 50 MHz clock rate.

A new data word pair is available at the output every clock cycle. All input and output data ports are registered, with a user-configurable phase accumulator structure and input register clock enables to simplify interfacing. The phase data range over a full 2π radians. All signals are TTL compatible.

Fabricated in a submicron CMOS process, the TMC2340A operates at the 50 MHz maximum clock rate over the full commercial temperature (0 to 70°C) and supply (4.75 to 5.25V) voltage ranges, and is available in low-cost 120 pin plastic pin grid array (PPGA) and a 120-lead metric quad flat pack (MQFP) package.

Logic Symbol

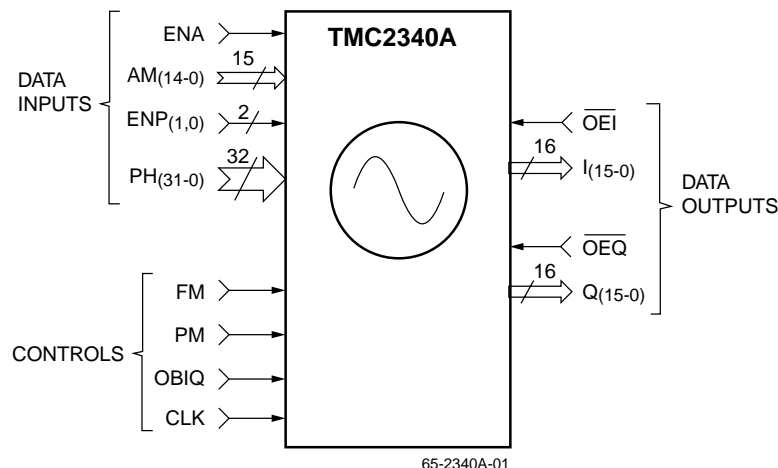

Block Diagram

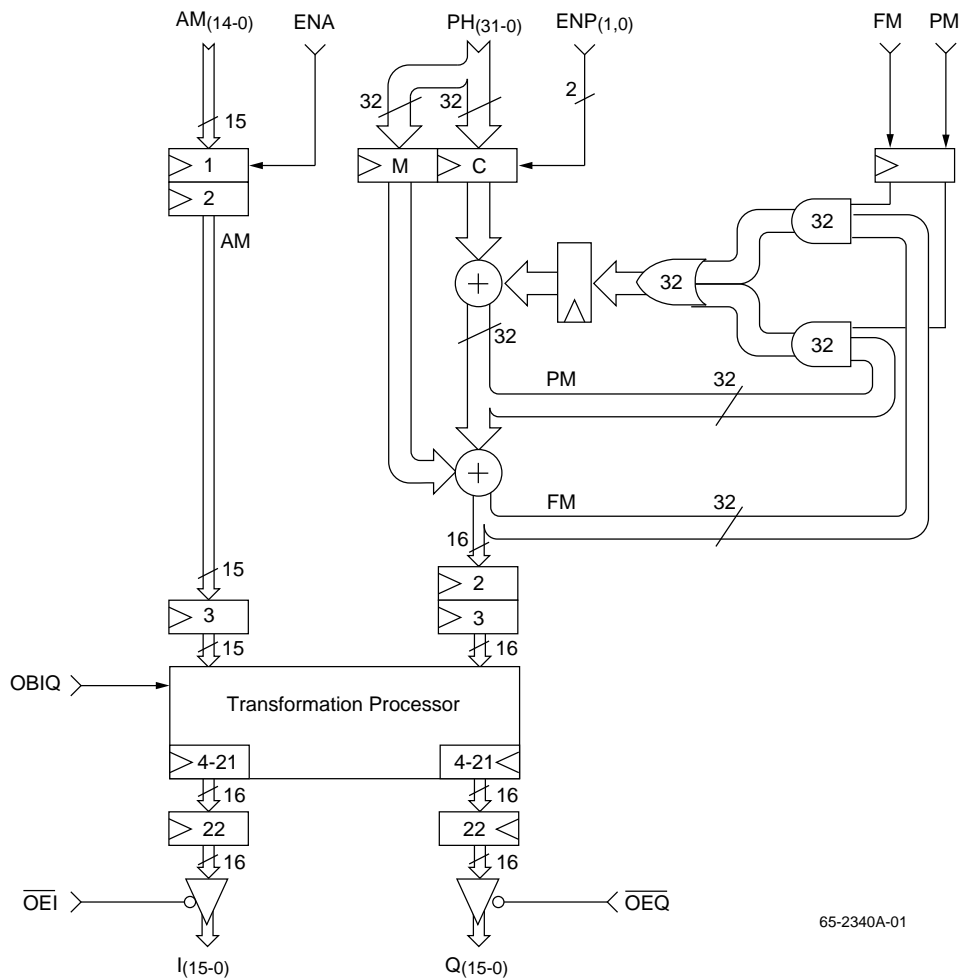

65-2340A-01

Functional Description

General Information

The TMC2340A converts Polar (Phase and Magnitude) data into Rectangular (Cartesian) format. The first transformed result is available at the outputs 22 clock cycles after startup, with new output data available every clock cycle. All input and output data ports are registered, with input clock enables to simplify system bus connections.

The input ports accept 15-bit amplitude and 32-bit phase data, and the output ports produce 16-bit Rectangular data

words in either 16-bit offset binary or 15-bit unsigned magnitude format. The 32-bit phase accumulator handles high-accuracy (0.012Hz at the maximum clock rate) phase increment values with minimal accumulation error. The flexible input phase accumulator structure supports frequency or phase modulation, as determined by the input register clock enable ENYP_{1,0} and accumulator controls FM and PM. The 16 MSBs (Most Significant Bits) of phase data are used in the transformation itself.

Table 1. Data Input/Output Formats – Integer Format

Port	OBIQ	BIT#												Format	
		31	30	29	.	.	.	16	15	14	.	.	.		0
AM	X									2^{14}	.	.	.	2^0	U
PH	X	$\pm 2^0$	2^{-1}	2^{-2}				2^{-15}	2^{-16}	2^{-17}	.	.	.	2^{-31}	($x\pi$) T/U
I	0									2^{14}	.	.	.	2^0	U
I	1							2^{15}	2^{14}	2^0	B
Q	0									2^{14}	.	.	.	2^0	U
Q	1							2^{15}	2^{14}	2^0	B

Notes:

- $\pm 2^0$ denotes two's complement sign or highest magnitude bit — since phase angles are modulo 2π and phase accumulator is modulo 2^{32} this bit may be regarded as $\pm\pi$.
- All phase angles are in terms of π radians, hence notation " $x\pi$."
- A sign-and-magnitude "Q" output is obtained by appending the input bit PH_{31} as a sign bit to the corresponding (i.e., delayed 22 cycles) Q_{14-0} .
- A sign-and-magnitude "I" output is obtained by appending the exclusive OR of PH_{31} and PH_{30} as a sign bit to the corresponding I_{14-0} .
- When OBIQ=0, outputs I_{15} and Q_{15} become "do not connect" and will stay at logic HIGH. (They may be wired to V_{DD} , left open, or connected to any logic input without damage to the part or excessive power consumption.)
- Formats:
T/U = Two's Complement/Unsigned Magnitude 32 Bits
U = Unsigned Magnitude 15 Bits
B = Offset Binary 16 Bits

AM, I, Q			PH	
HEX	U	B	T	U
FFFF		32767	$-\pi \cdot 2^{-15}$	$\pi(2-2^{-15})$
--	--	--		
8001		1	$-\pi(1-2^{-15})$	$\pi(1+2^{-15})$
8000		0	$-\pi$	π
7FFF	32767	-1	$\pi(1-2^{-15})$	$\pi(1-2^{-15})$
--	--	--		
0001	1	-32767	$\pi \cdot 2^{-15}$	$\pi \cdot 2^{-15}$
0000	0	-32768	0	0

"Hex" column contains the 16 MSBs of the 32-bit phase input (16 LSBs are 0), the 15 bits of the amplitude input or the 16 bits of the offset binary output

Static Control Input

OBIQ determines the numeric format of the output data: offset binary if HIGH and unsigned magnitude if LOW. This

control acts with 2-cycle latency on the chip's 22-cycle data path and is normally hardwired to a system-specific state.

Pin Assignments

120-Pin Plastic Pin Grid Array (PPGA)

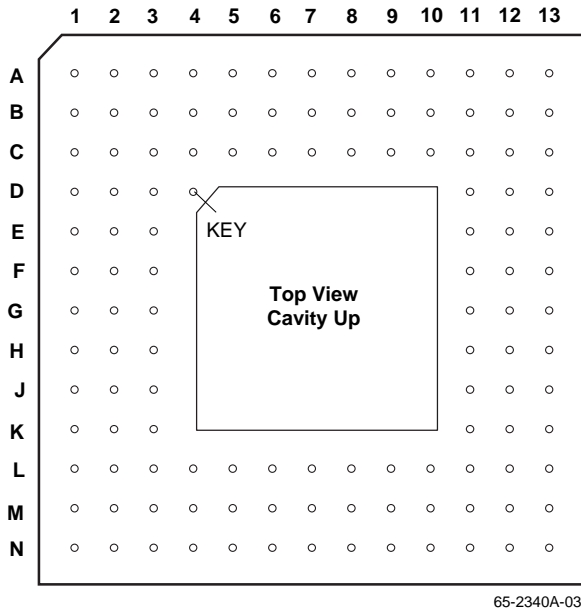

Pin	Name	Pin	Name	Pin	Name	Pin	Name
A1	Q5	C5	GND	G11	GND	L10	PH31
A2	Q7	C6	V _{DD}	G12	AM12	L11	V _{DD}
A3	Q8	C7	GND	G13	AM13	L12	AM3
A4	Q10	C8	V _{DD}	H1	PM	L13	AM4
A5	Q12	C9	GND	H2	FM	M1	PH6
A6	Q14	C10	GND	H3	V _{DD}	M2	PH9
A7	Q15	C11	V _{DD}	H11	AM9	M3	PH11
A8	I ₀	C12	I ₁₁	H12	AM10	M4	PH13
A9	I ₂	C13	I ₁₃	H13	AM11	M5	PH16
A10	I ₄	D1	OE _Q	J1	PH ₀	M6	PH18
A11	I ₆	D2	Q ₀	J2	PH ₁	M7	PH20
A12	I ₈	D3	GND	J3	PH ₃	M8	PH23
A13	I ₁₀	D11	GND	J11	GND	M9	PH25
B1	Q ₃	D12	I ₁₄	J12	AM7	M10	PH28
B2	Q ₄	D13	I ₁₅	J13	AM8	M11	ENA
B3	Q ₆	E1	GND	K1	PH ₂	M12	AM ₁
B4	Q ₉	E2	GND	K2	PH ₄	M13	AM ₂
B5	Q ₁₁	E3	V _{DD}	K3	GND	N1	PH ₈
B6	Q ₁₃	E11	V _{DD}	K11	GND	N2	PH ₁₀
B7	GND	E12	GND	K12	AM ₅	N3	PH ₁₂
B8	I ₁	E13	OE _I	K13	AM ₆	N4	PH ₁₅
B9	I ₃	F1	OBIO	L1	PH ₅	N5	PH ₁₇
B10	I ₅	F2	GND	L2	PH ₇	N6	PH ₁₉
B11	I ₇	F3	CLK	L3	GND	N7	PH ₂₁
B12	I ₉	F11	V _{DD}	L4	V _{DD}	N8	PH ₂₂
B13	I ₁₂	F12	GND	L5	PH ₁₄	N9	PH ₂₄
C1	Q ₁	F13	AM ₁₄	L6	V _{DD}	N10	PH ₂₆
C2	Q ₂	G1	ENP ₁	L7	GND	N11	PH ₂₉
C3	V _{DD}	G2	ENP ₀	L8	V _{DD}	N12	PH ₃₀
C4	GND	G3	GND	L9	PH ₂₇	N13	AM ₀

Pin Assignments (continued)

120-Lead Metric Quad Flat Pack (MQFP)

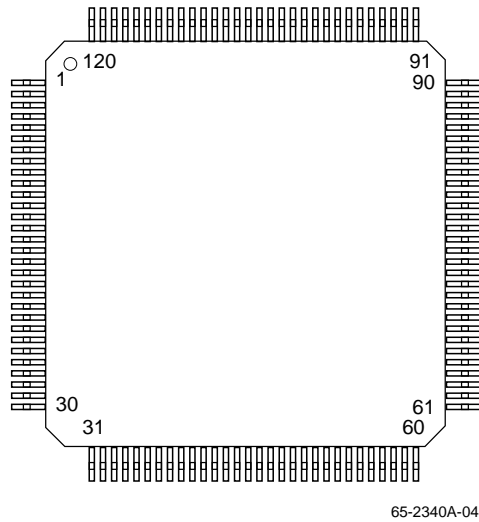

Pin	Name	Pin	Name	Pin	Name	Pin	Name
1	VDD	31	GND	61	VDD	91	VDD
2	Q ₄	32	PH ₉	62	AM ₁	92	I ₉
3	Q ₃	33	PH ₁₀	63	AM ₂	93	I ₈
4	GND	34	VDD	64	GND	94	GND
5	Q ₂	35	PH ₁₁	65	AM ₃	95	I ₇
6	Q ₁	36	PH ₁₂	66	AM ₄	96	I ₆
7	Q ₀	37	PH ₁₃	67	AM ₅	97	I ₅
8	VDD	38	PH ₁₄	68	GND	98	GND
9	QEQ	39	PH ₁₅	69	AM ₆	99	I ₄
10	GND	40	PH ₁₆	70	AM ₇	100	I ₃
11	GND	41	PH ₁₇	71	AM ₈	101	I ₂
12	CLK	42	VDD	72	AM ₉	102	VDD
13	GND	43	PH ₁₈	73	AM ₁₀	103	I ₁
14	OBIQ	44	PH ₁₉	74	AM ₁₁	104	I ₀
15	ENP ₀	45	PH ₂₀	75	AM ₁₂	105	GND
16	GND	46	GND	76	GND	106	GND
17	ENP ₁	47	PH ₂₁	77	AM ₁₃	107	Q ₁₅
18	PM	48	PH ₂₂	78	AM ₁₄	108	Q ₁₄
19	FM	49	PH ₂₃	79	GND	109	Q ₁₃
20	VDD	50	VDD	80	VDD	110	VDD
21	PH ₀	51	PH ₂₄	81	QEI	111	Q ₁₂
22	PH ₁	52	PH ₂₅	82	GND	112	Q ₁₁
23	PH ₂	53	PH ₂₆	83	I ₁₅	113	Q ₁₀
24	PH ₃	54	PH ₂₇	84	VDD	114	GND
25	PH ₄	55	PH ₂₈	85	I ₁₄	115	Q ₉
26	PH ₅	56	PH ₂₉	86	I ₁₃	116	Q ₈
27	PH ₆	57	PH ₃₀	87	I ₁₂	117	Q ₇
28	GND	58	PH ₃₁	88	GND	118	GND
29	PH ₇	59	ENR	89	I ₁₁	119	Q ₆
30	PH ₈	60	AM ₀	90	I ₁₀	120	Q ₅

Pin Descriptions

Pin Name	Pin Number		Pin Function Description
	PPGA	MQFP	
Power, Ground and Clock			
VDD	C3, E3, H3, L4, L6, L8, L11, F11, E11, C11, C8, C6	1, 8, 20, 34, 42, 50, 61, 80, 84, 91, 102, 110	The TMC2340A operates from a single +5V supply. All power and ground pins must be connected.
GND	D3, E2, E1, F2, G3, K3, L3, L7, K11, J11, G11, F12, E12, D11, C10, C9, B7, C7, C5, C4	4, 10, 11, 13, 16, 28, 31, 46, 64, 68, 76, 79, 82, 88, 94, 98, 105, 106, 114, 118	Ground
CLK	F3	12	The TMC2340A operates from a single clock. All enabled registers are strobed on the rising edge of CLK, which is the reference for all timing specifications.

Pin Descriptions (continued)

Pin Name	Pin Number		Pin Function Description										
	PPGA	MQFP											
Inputs/Outputs													
AM ₁₄₋₀	F13, G13, G12, H13, H12, H11, J13, J12, K13, K12, L13, L12, M13, M12, N13	78, 77, 75-69, 67-65, 63, 62, 60	AM ₁₄₋₀ is the registered peak amplitude 15-bit input data port. AM ₁₄ is the MSB.										
PH ₃₁₋₀	L10, N12, N11, M10, L9, N10, M9, N9, M8, N8, N7, M7, N6, M6, N5, M5, N4, L5, M4, N3, M3, N2, M2, N1, L2, M1, L1, K2, J3, K1, J2, J1	58-51, 49-47, 45-43, 41-35, 33, 32, 30, 29, 27-21	PH ₃₁₋₀ is the registered Phase angle increment 32-bit input data port. The input phase accumulators are fed through this port in conjunction with the input enable select ENP _{1,0} . PH ₃₁ is the MSB.										
I ₁₅₋₀	D13, D12, C13, B13, C12, A13, B12, A12, B11, A11, B10, A10, B9, A9, B8, A8	83, 85, 86, 87, 89, 90, 92, 93, 95-97, 99-101, 103, 104	I ₁₅₋₀ is the registered X-coordinate 16-bit output data port. This output is forced into the high-impedance state when \overline{OEI} =HIGH. I ₀ is the LSB. I ₁₅ will be "stuck at" logic HIGH if OBIQ=0.										
Q ₁₅₋₀	A7, A6, B6, A5, B5, A4, B4, A3, A2, B3, A1, B2, B1, C2, C1, D2	107-109, 111-113, 115-117, 119, 120, 122, 123, 125-127	Q ₁₅₋₀ is the registered Cartesian Y-coordinate 16-bit output data port. This output is forced to the high-impedance state when \overline{OEQ} =HIGH. Q ₀ is the LSB. Q ₁₅ will remain at logic HIGH if OBIQ=0.										
Controls													
ENA	M11	59	Data presented to the input port AM are latched into the input registers on the current clock when ENA is HIGH. When ENA is LOW, the data stored in the register remains unchanged.										
ENP _{1,0}	G1, G2	17, 15	<p>The value presented to the PH input port is latched into the phase accumulator input registers on the current clock, as determined by the control inputs ENP_{1,0}, as shown below:</p> <table border="1" style="margin-left: 20px;"> <thead> <tr> <th>ENP_{1,0}</th> <th>Instruction</th> </tr> </thead> <tbody> <tr> <td>00</td> <td>No registers enabled, current data held</td> </tr> <tr> <td>01</td> <td>M register input enabled, C data held</td> </tr> <tr> <td>10</td> <td>C register input enabled, M data held</td> </tr> <tr> <td>11</td> <td>M register set to 0, C register input enabled</td> </tr> </tbody> </table> <p>where C is the Carrier register and M is the Modulation register, and 0=LOW, 1= HIGH. See the Block Diagram.</p>	ENP _{1,0}	Instruction	00	No registers enabled, current data held	01	M register input enabled, C data held	10	C register input enabled, M data held	11	M register set to 0, C register input enabled
ENP _{1,0}	Instruction												
00	No registers enabled, current data held												
01	M register input enabled, C data held												
10	C register input enabled, M data held												
11	M register set to 0, C register input enabled												

Pin Descriptions (continued)

Pin Name	Pin Number		Pin Function Description										
	PPGA	MQFP											
FM, PM	H2, H1	19, 18	<p>The user determines the internal phase Accumulator structure implemented on the next clock by setting the accumulator control word FM, PM, as shown below:</p> <table border="1"> <thead> <tr> <th>FM, PM</th> <th>Instruction</th> </tr> </thead> <tbody> <tr> <td>00</td> <td>No accumulation performed</td> </tr> <tr> <td>01</td> <td>PM accumulator path enabled</td> </tr> <tr> <td>10</td> <td>FM accumulator path enabled</td> </tr> <tr> <td>11</td> <td>(Nonsensical) logical OR of PM and FM</td> </tr> </tbody> </table> <p>where 0=LOW, 1=HIGH. See the Block Diagram.</p> <p>The accumulator will roll over correctly when full-scale is exceeded, allowing the user to perform continuous phase accumulation through 2π radians, or 360 degrees.</p>	FM, PM	Instruction	00	No accumulation performed	01	PM accumulator path enabled	10	FM accumulator path enabled	11	(Nonsensical) logical OR of PM and FM
FM, PM	Instruction												
00	No accumulation performed												
01	PM accumulator path enabled												
10	FM accumulator path enabled												
11	(Nonsensical) logical OR of PM and FM												
OBIQ	F1	14	<p>The format select control sets the numeric format of the Rectangular data: offset binary format when HIGH, and unsigned when LOW. This is a static input. See the Timing Diagram.</p>										
\overline{OEI} , \overline{OEQ}	E13, D1	81, 9	<p>Data in the output registers are available at the outputs of the device when the respective asynchronous Output Enables are LOW. When \overline{OEI} or \overline{OEQ} is HIGH, the respective output port is in the high-impedance state.</p>										

Absolute Maximum Ratings

(beyond which the device may be damaged)¹

Parameter	Min	Max	Units
Power Supply Voltage (VCC)	-0.5	7	V
Input Voltage	-0.5 to (VDD+0.5)V		
Applied Voltage ² Output	-0.5	VDD+0.5	
Externally Forced Current Output			
Short-circuit Duration Output (single output in HIGH state to ground)		1 second	
Operating Temperature	-20	110	°C
Storage Temperature	-65	150	°C
Junction Temperature		140	°C
Lead Soldering Temperature (10 sec)		300	°C

Notes:

- Absolute maximum ratings are limiting values applied individually while all other parameters are within specified operating conditions. Functional operation under any of these conditions is NOT implied. Performance and reliability are guaranteed only if Operating Conditions are not exceeded.
- Applied voltage must be current limited to specified range.
- Forcing voltage must be limited to specified range.
- Current is specified as conventional current flowing into the device.

Operating Conditions

Parameter		Condition	Min	Nom	Max	Units
V _{DD}	Power Supply Voltage		4.75	5.0	5.25	V
f _{CLK}	Clock frequency	TMC2340A TMC2340A-1 TMC2340A-2			20 40 50	MHz MHz MHz
t _{PWH}	Clock Pulse Width, HIGH		7			ns
t _{PWL}	Clock Pulse Width, LOW		6			ns
t _S	Input Data Setup Time		6			ns
t _H	Input Data Hold Time		1			ns
V _{IH}	Input Voltage, Logic HIGH		2.0			V
V _{IL}	Input Voltage, Logic LOW				0.8	V
I _{OH}	Output Current, Logic HIGH				-2.0	mA
I _{OL}	Output Current, Logic LOW				4.0	mA
T _A	Ambient Temperature, Still Air		0		70	°C

Electrical Characteristics

Parameter		Conditions	Min	Nom	Max	Units
I _{DD}	Power Supply Current	V _{DD} = Max, C _{LOAD} = 25pF, f _{CLK} = Max TMC2340A TMC2340A-1 TMC2340A-2			140 240 290	mA mA mA
I _{DDU}	Power Supply Current, Unloaded	V _{DD} = Max, $\overline{OE1}$, \overline{OEQ} = HIGH, f _{CLK} = Max TMC2340A TMC2340A-1 TMC2340A-2			95 175 215	mA mA mA
I _{DDQ}	Power Supply Current, Quiescent	V _{DD} = Max, CLK = LOW			5	mA
C _{PIN}	I/O Pin Capacitance			5		pF
I _{IH}	Input Current, HIGH	V _{DD} = Max, V _{IN} = V _{DD}			±10	μA
I _{IL}	Input Current, LOW	V _{DD} = Max, V _{IN} = 0 V			±10	μA
I _{OZH}	Hi-Z Output Leakage Current, Output HIGH	V _{DD} = Max, V _{IN} = V _{DD}			±10	μA
I _{OZL}	Hi-Z Output Leakage Current, Output LOW	V _{DD} = Max, V _{IN} = 0 V			±10	μA
I _{OS}	Short-Circuit Current		-20		-80	mA
V _{OH}	Output Voltage, HIGH	I _{OH} = Max	2.4			V
V _{OL}	Output Voltage, LOW	I _{OL} = Max			0.4	V

Switching Characteristics

Parameter		Conditions ¹	Min	Nom	Max	Units
t _{DO}	Output Delay Time	C _{LOAD} = 25 pF			16	ns
t _{HO}	Output Hold Time	C _{LOAD} = 25 pF	3			ns
t _{ENA}	Three-State Output Enable Delay	C _{LOAD} = 0 pF			13	ns
t _{DIS}	Three-State Output Disable Delay	C _{LOAD} = 0 pF			13	ns

Note:

1. All transitions are measured at a 1.5V level except for t_{ENA} and t_{DIS}.

Timing Diagram – No Accumulation

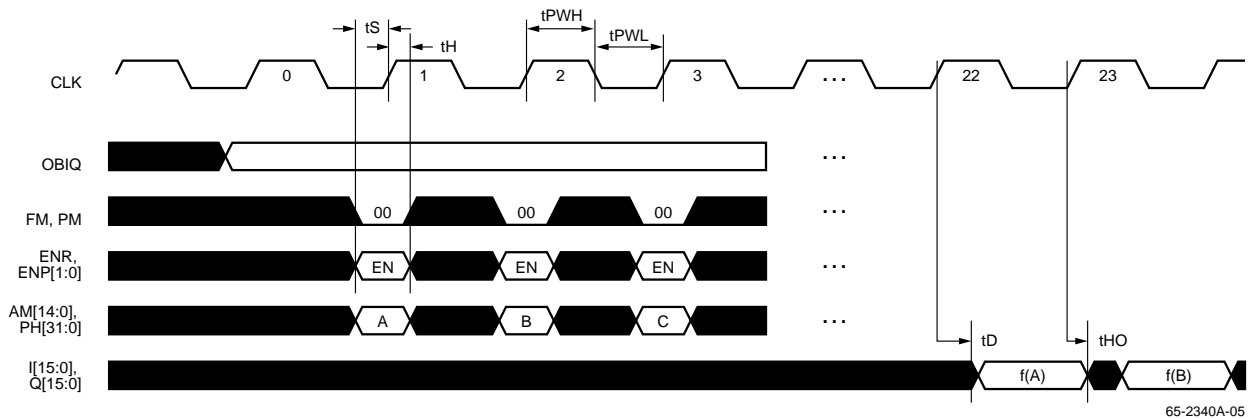

65-2340A-05

Note: \overline{OEI} , \overline{OEQ} = LOW.

Timing Diagram – Phase Modulation

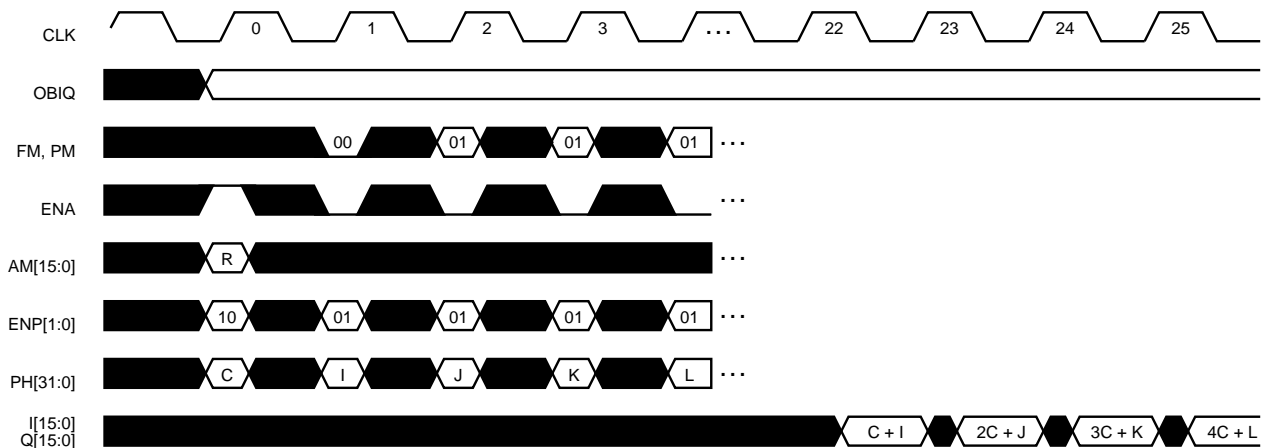

65-2340A-06

Notes:

1. \overline{OEI} , \overline{OEQ} = LOW.
2. Carrier C and peak amplitude A loaded on CLK 0.
3. Modulation values I, J, K, L, ... loaded on CLK 1, CLK 2, etc.
4. Output corresponding to modulation loaded at CLK i emerged t_{DO} after CLK i +21.
5. To modulate amplitude, vary AM with ENA = 1.

Equivalent Circuits and Transition Levels

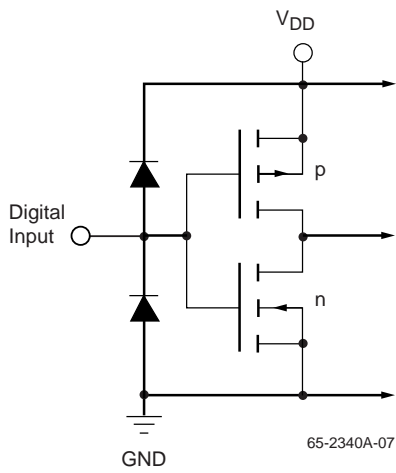

Figure 1. Equivalent Input Circuit

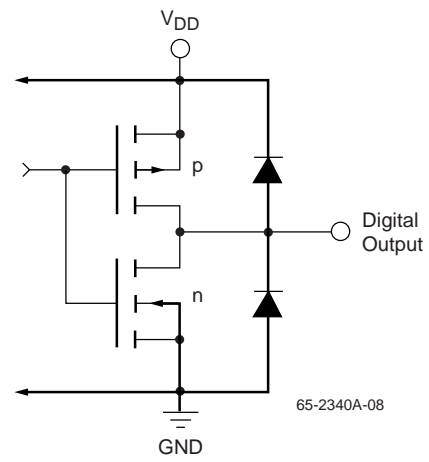

Figure 2. Equivalent Output Circuit

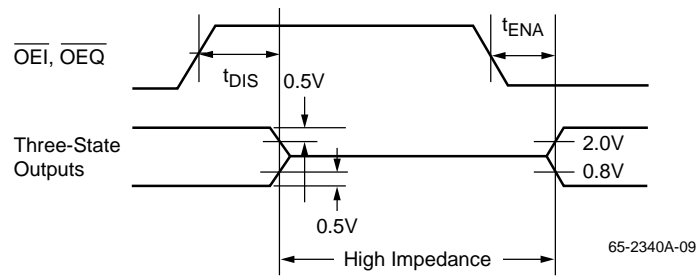

Figure 3. Transition Levels for Three-State Measurements

Digital Waveform Synthesis

Generating Unmodulated Sine and Cosine Waves

The TMC2340 can generate simultaneous quadrature-matched sine and cosine waves with optional amplitude, frequency, or phase modulation. To obtain an unmodulated waveform, the user loads the desired phase step value, computed as:

$$f_C = \frac{2^{32} \times \text{desired_output_frequency}}{\text{digital_clock_frequency}}$$

into the 32-bit-wide carrier register via the PH input port, and applies the desired sinusoid amplitude (half of the desired peak-to-peak value) to the 15-bit-wide AM input port. As the chip's internal phase accumulator increments linearly in steps of f_C , the chip will output a series of complex number pairs representing the horizontal and vertical projections of a vector rotating about the origin, i.e., cosine and sine waves.

A procedure that will yield continuous unmodulated sinusoids is shown in Table 2.

Table 2. Generating unmodulated sinusoids

FM	PM	ENA	AM	ENP	PH	
0	0	1	a	11	f_C	loads freq & amplitude
0	1	0	x	00	x	starts synthesizer @ phase = f_C
0	1	0	x	00	x	continues @ phase = $2f_C$

Because the chip's internal pipeline is 22 registers deep, the effects of any given set of data inputs or instructions won't be seen for 22 clock cycles. After the $(22+n)$ th rising edge of the system clock, the outputs will be (Figure 4):

$$I(22 + n) = a \cos(2\pi n f_C / 2^{32}) \text{ and}$$

$$Q(22 + n) = a \sin(2\pi n f_C / 2^{32}),$$

where a is the (constant) amplitude and f_C is the (constant) carrier phase step or frequency ratio. For example, if we arbitrarily set $a=4000h$ and $f_C=2000\ 0000h$, the chip will generate quadrature-matched sines and cosines at 1/8 of the

clock frequency and 1/2 of full-scale amplitude. Here, the internal phase accumulation sequence will be:

Phase Accumulator	Phase
2000 0000h	45 degrees
4000 0000h	90
6000 0000h	135
8000 0000h	180
a000 0000h	225
c000 0000h	270
e000 0000h	315
0000 0000h	0
2000 0000h	45
•••	•••

On any given clock cycle, the phase angle into the chip's polar-to-rectangular converter core is that of the phase accumulator:

$$\text{phase}(n) = n f_C$$

[The maximum possible output frequency is just less than half of the clock rate, per the Nyquist limit. For $f > 8000\ 0000$, one obtains "negative" frequencies, because the phase increment now aliases backward. Thus, $a=4000h$ and $f=e000\ 0000h$ will generate a cosine wave and a negated sine wave at 1/8 of the clock frequency and 1/2 of full-scale amplitude.]

Amplitude Modulation

By holding amplitude enable pin ENA high, the user can vary the incoming amplitude sample by sample, thereby amplitude-modulating the output signals. The output equations become:

$$I(22 + n) = a(n) \times \cos(2\pi n f_C / 2^{32}) \text{ and}$$

$$Q(22 + n) = a(n) \times \sin(2\pi n f_C / 2^{32}),$$

Most amplitude modulation applications employ an external adder to combine a fixed (unsigned magnitude) carrier amplitude with a sample-by-sample two's complement modulation term, such that the chip sees:

$$a(n) = \text{carrier_amplitude} + \text{amplitude_modulation}(n)$$

[Since the chip accepts only nonnegative amplitudes, this simple implementation is limited to 100% modulation, wherein the instantaneous incoming amplitude can drop to 0, but not below.]

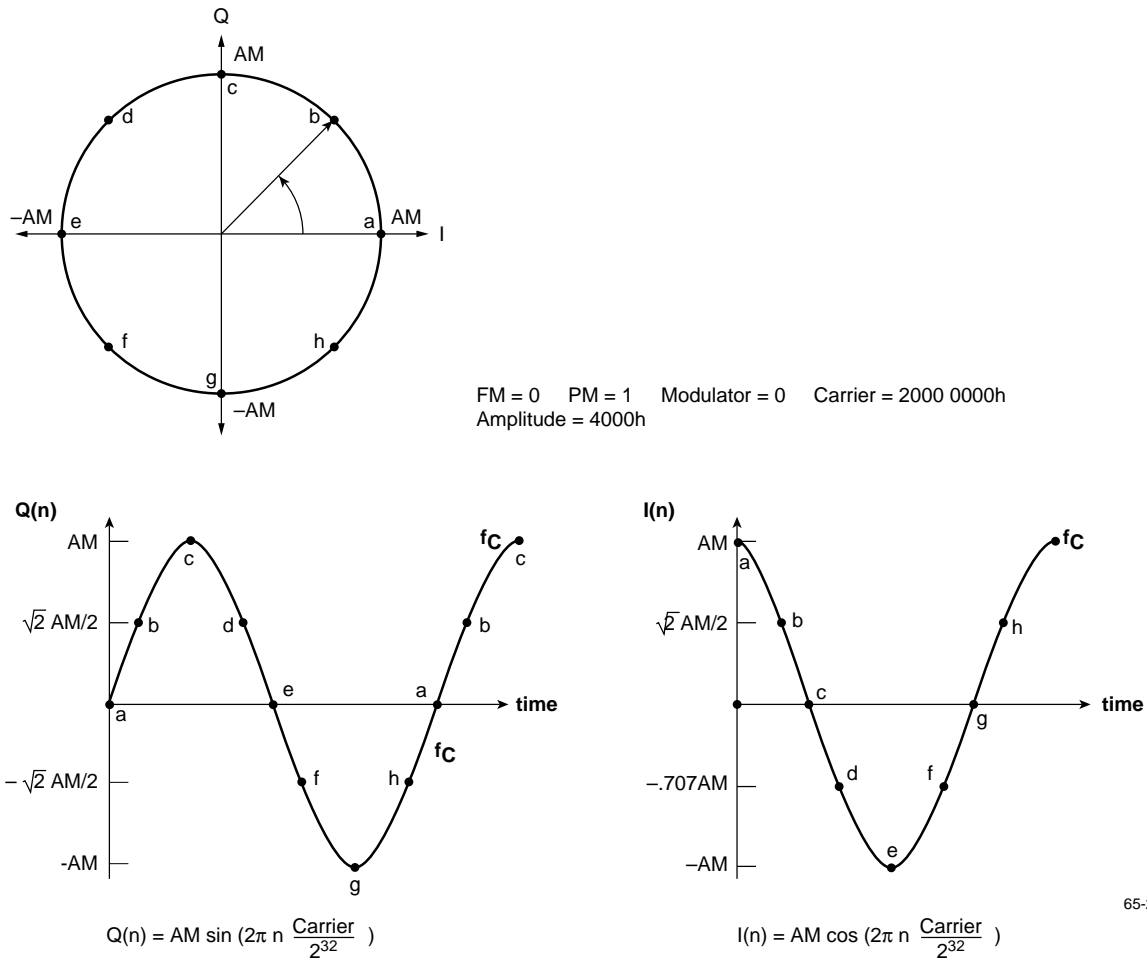

Figure 4. Unmodulated Sinusoid Generation

Again, on any given clock cycle, the phase angle into the chip’s polar-to-rectangular converter core is that of the phase accumulator:

$$\text{phase}(n) = nfc$$

Phase Modulation

By setting ENP to 10 instead of 00 (while keeping FM = 0 and PM = 1), the user can load a new modulating phase shift into the PH port on each clock cycle. If we label this modulating term p(n), the output equations become:

$$I(n+22) = a(n) \times \cos(2\pi(p(n)+nfc)/2^{32})$$

$$Q(n+22) = a(n) \times \sin(2\pi(p(n)+nfc)/2^{32})$$

Figure 5 depicts the internal subsarrier architecture in this mode. If we again load carrier = 2000 0000h, but now alternately apply phase modulation (p) terms 0 and 1000 000h, the internal phase sequence will be:

Phase Modulation	Phase
2000 0000h	normal unmodulated start
5000 0000h	phase advanced by an additional 1000 0000h
6000 0000h	phase back to normal progression
9000 0000h	phase advanced by an additional 1000 0000h
a000 0000h	phase back to normal progression
d000 0000h	phase advanced by an additional 1000 0000h
e000 0000h	phase back to normal progression

Here, on any given clock cycle, the phase angle into the chip’s polar-to-rectangular converter core is that of the phase accumulator, plus the current value of the modulator:

$$\text{phase}(n) = nfc + p(n)$$

Frequency Modulation

By setting ENP = 10, FM = 1, and PM = 0, the user can load a new frequency modulation sample into the PH port on each clock cycle. In phase modulation, the angular modulation term was outside of the phase accumulator/integration loop. Therefore, each modulation sample affected only a single complex output sample. In frequency modulation, since the angular modulation occurs within the phase accumulator, each modulation sample affects all future outputs. Figure 5 depicts the phase accumulator architecture in this mode.

Consider the following phase advance sequence, using the same 2000 0000h carrier and alternate 0 and 1000 000h modulation, this time in frequency modulation instead of phase modulation mode:

Phase Accumulator	Phase
2000 0000h	unmodulated
5000 0000h	phase advanced by 10000000+20000000
7000 0000h	unmodulated—phase advanced by 20000000
a000 0000h	phase again advanced by 30000000
c000 0000h	advance by 20000000
f000 0000h	advance by 30000000

Here, on any given clock cycle, the phase angle into the chip’s polar-to-rectangular converter core is that of the previous cycle, plus carrier + modulator:

$$\text{phase}(n+1) = \text{phase}(n) + fC + p(n)$$

and is the same as the present value in phase accumulator. In frequency modulation mode, introducing a single nonzero modulation term will shift the phases of all outputs which follow. In contrast, in phase modulation, introducing a single nonzero modulation term will shift the phase of only one output.

Digital Synthesizer with the TDC1012 D/A Converter

The TDC1012 is an ideal D/A converter for digital synthesis, exhibiting a Spurious-Free Dynamic Range of greater than 70dB. Connection between the TMC2340A and TDC1012 is straightforward, as illustrated in Figure 5.

Either the I or the Q output of the TMC2340 may be connected to the D/A; two converters are used for quadrature synthesis. The trans-former-coupled output circuit shown is recommended for minimum distortion. See the TDC1012 datasheet for details.

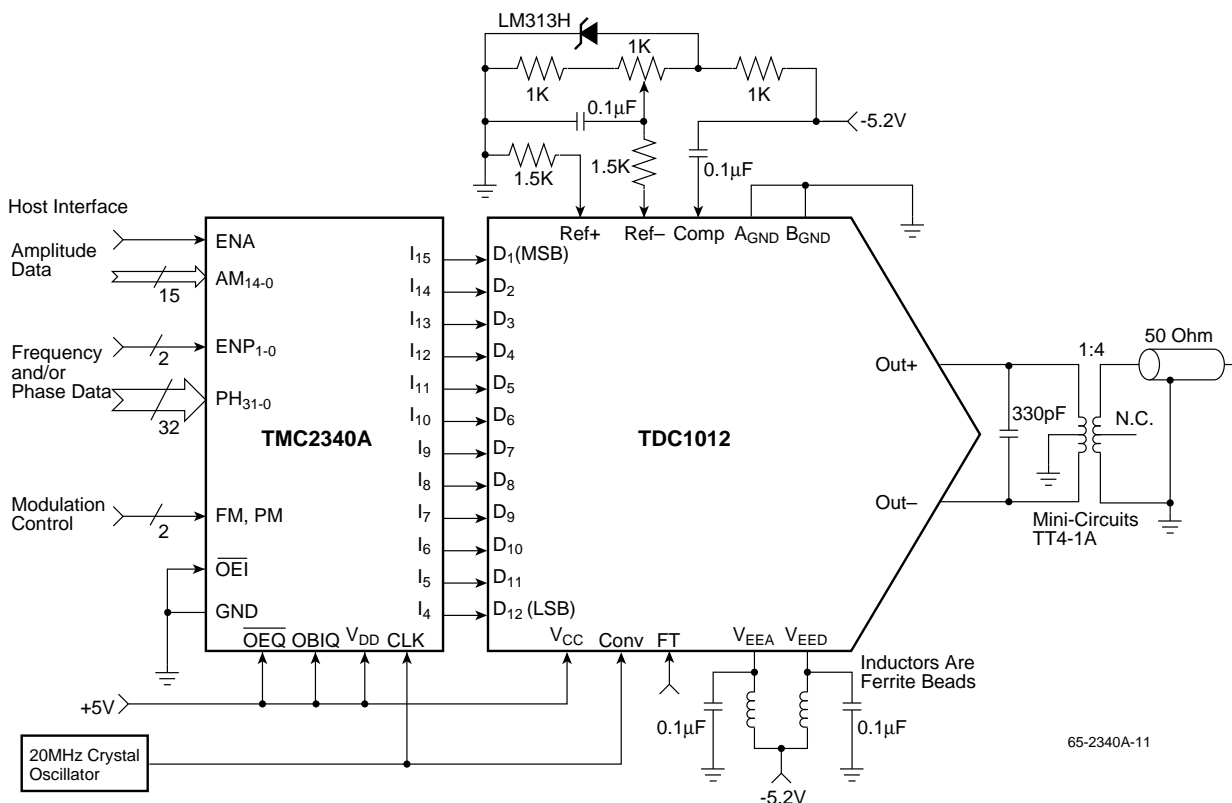

Figure 5. Frequency Synthesizer

65-2340A-11

Control of the TMC2340A

The TMC2340A needs to be initialized to tell it what frequency and amplitude sinusoid to generate. To initialize amplitude, apply the desired full-scale amplitude to the AM input port of the TMC2340A (AM₁₄ through AM₀) and pull ENA HIGH for one clock cycle. This will load the amplitude. If ENA is held HIGH, then the amplitude will follow the inputs on the AM port. If the user assumes an implied binary point before the MSB of the AM port, the input range will be 0 to just under 1, and the outputs will fall between 0 and 2, with binary points after I₁₅ and Q₁₅.

To set the frequency, the C register must be loaded with a value which is the phase increment per clock cycle. If the binary point is considered to be just left of the MSB (input range is 0 to almost 1) then the output frequency is the TMC2340A clock frequency multiplied by the number loaded into C. Since C is 32 bits wide, with a 20MHz clock, one LSB represents a frequency increment of 0.005Hz.

To load the C register, set ENYP₁=1 and ENYP₀=0; the data presented at the PH port will be loaded on the next clock rising edge.

At this point the TMC2340A has been initialized and can be put into one of three modes depending upon the states of FM and PM:

Mode 0 FM = 0, PM = 0

In this mode the chip is in standby. The unchanging output corresponds to AM cos(PM) on the I outputs with PM being the phase increment.

Mode 1 FM=1, PM=0

Frequency Modulation Mode. The chip generates an output signal of peak amplitude AM and frequency determined by accumulating the sum of the phase increment values in the C and M registers (more about the M register in a later section).

Mode 2 FM=0, PM=1

Phase Modulation Mode. The TMC2340A generates a sinusoid of the frequency represented in the C register and the peak amplitude in the AM register. On each clock cycle, the phase of the signal is offset by the value in the M register. Use this mode with ENP=00 for unmodulated sine wave synthesis.

Modulation

The output of the TMC2340A can be phase (Mode 2) or frequency (Mode 1) modulated. An unmodulated sinusoid results if the contents of registers C and M are held constant. Its frequency is set by C (Mode 2) or C+ M (Mode 1). Since the state of the M register is not defined at power up, the M register should be loaded or cleared to begin operation.

If the signal is to be frequency modulated then the modulation signal is loaded into the M register. The format for the

frequency is the same as that for the C register.

If ENYP₁, 0 = 0, 1 then the data value present at the PH port is automatically loaded on each clock rising edge.

For phase modulation, the phase deviation is loaded into the M register (same manner as for frequency modulation). The units of the phase offset are cycles and full-scale is just under one output cycle per TMC2340A clock cycle. The MSB represents a phase of 180°, and the LSB a phase of about 8×10^{-8} degrees (eight one-hundred millionths of a degree) or $\pi/2^{31}$ radians.

To synchronize two TMC2340As, first load them with their respective data in mode 0, then switch them simultaneously to either Mode 1 or Mode 2.

Calculating Frequency, Amplitude, and Phase Input Values for the TMC2340A

This Application Brief discusses equations which simplify the calculation of register values which control the TMC2340A. These values allow the generation of output carrier frequency, frequency or phase modulation, and output amplitude.

The results of the equations are converted to binary register values and should be rounded to the resolution of the applicable register (32 or 15-bits). For negative values of phase or frequency modulation, use these equations for positive values and see Table 1 to convert them to negative values.

The TMC2340A operates by continuously incrementing a register (phase accumulator) that rolls over when it becomes full. For example, if the next increment to the phase accumulator causes it to overflow by 47 LSBs, the phase accumulator retains the value 47. The value present in the carrier register (C) is the amount by which the phase accumulator is incremented each system clock cycle. As the value of the carrier register is increased, the value with which the phase accumulator is incremented each clock cycle is increased, resulting in an increased carrier frequency.

The magnitude of the carrier is determined or modulated by the value loaded in the AM register. Phase modulation is accomplished by adding the value of the phase accumulator to the value of the modulation (M) register. This adds an offset to the phase of the carrier. This does not affect the increment value of the phase accumulator and therefore affects only the phase of the carrier, leaving the frequency constant.

Adding the value of the modulation register to the phase accumulator along with the value of the carrier register on each clock cycle results in a shift in frequency. This is because the phase accumulator is incremented by a different amount each clock cycle.

Frequency or phase modulation is selected with the FM and PM input pins which configure the TMC2340A. The equations presented herein are useful for setting carrier frequency

and phase, output amplitude, and frequency and phase modulation. To modulate the carrier with an external signal, the signal must be digitized and those values loaded into the modulation inputs of the TMC2340A.

The carrier and modulation registers are loaded through the PH₃₁₋₀ inputs. The ENP_{1,0} inputs select the desired register. The amplitude register is loaded through the AM₁₄₋₀ inputs.

CARRIER FREQUENCY:

$$\text{Carrier Register (C) Value} = \frac{\text{Desired Carrier Frequency}}{\text{Clock Frequency}} \times 2^{32}$$

AMPLITUDE AND AMPLITUDE MODULATION:

$$\text{AM Register Value} = \frac{\text{Desired Output Amplitude}}{\text{Full-Scale Output Amplitude}} \times (2^{15} - 1)$$

FREQUENCY MODULATION:

$$\text{Modulation Register (M) Value} = \frac{\text{Desired Change in Carrier Frequency}}{\text{Clock Frequency}} \times 2^{32}$$

PHASE-MODULATION:

$$\text{Modulation Register (M) Value} = \frac{\text{Desired Change in Phase in Radians (Degrees)}}{2\pi(360^\circ)} \times 2^{32}$$

EXAMPLE 1: Set carrier frequency to 3.579545 MHz with a system clock of 20MHz.

$$\text{Carrier Register (C) Value} = \frac{\text{Desired Carrier Frequency}}{\text{Clock Frequency}} \times 2^{32} = \frac{3.579545 \times 10^6}{20 \times 10^6} \times 2^{32}$$

$$C = 0.17897725 \times 4,294,967,296 = 768,701,436 = 2DD1\ 73FCh$$

$$= 0010\ 1101\ 1101\ 0001\ 0111\ 0011\ 1111\ 1011 = PH_{31-0}$$

EXAMPLE 2: Set output amplitude to be 12.2% of full-scale.

$$\text{AM Register Value} = \frac{\text{Desired Output Amplitude}}{\text{Full-Scale Output Amplitude}} \times (2^{15} - 1) = \frac{12.2}{100.0} \times 32767$$

$$AM = 3,998 = 0F9Eh = 0001\ 1111\ 0011\ 1100 = AM_{14-0}$$

EXAMPLE 3: Change carrier frequency by 10kHz with a system clock of 3 MHz.

$$\text{Modulation Register (M) Value} = \frac{\text{Desired Change in Carrier Frequency}}{\text{Clock Frequency}} \times 2^{32}$$

$$M = \frac{10 \times 10^3}{3 \times 10^6} \times 2^{32} = 14,316,558 = 00DA\ 740Eh$$

$$M = 0000\ 0000\ 1101\ 1010\ 0111\ 0100\ 0000\ 1110 = PH_{31-0}$$

EXAMPLE 4: Advance the phase of any carrier frequency by 12°.

$$\text{Modulation Register (M) Value} = \frac{\text{Desired Change in Phase}}{360^\circ} \times 2^{32} = \frac{12}{360} \times 2^{32}$$

$$M = 0.0333333 \times 2^{32} = 143,165,577 = 0888\ 8889h$$

$$= 0000\ 1000\ 1000\ 1000\ 1000\ 1000\ 1001 = PH_{31-0}$$

Notes:

Notes:

Mechanical Dimensions

121-Pin PPGA Package

Symbol	Inches		Millimeters		Notes
	Min.	Max.	Min.	Max.	
A	.080	.160	2.03	4.06	
A1	.040	.060	1.01	1.53	
A2	.125	.215	3.17	5.46	
øB	.016	.020	0.40	0.51	2
øB2	.050 NOM.		1.27 NOM.		2
D	1.340	1.380	33.27	35.05	SQ
D1	1.200 BSC		30.48 BSC		
e	.100 BSC		2.54 BSC		
L	.110	.145	2.79	3.68	
L1	.170	.190	4.31	4.83	
M	13		13		3
N	120		120		4
P	.003	—	.076	—	

Notes:

1. Pin #1 identifier shall be within shaded area shown.
2. Pin diameter excludes solder dip finish.
3. Dimension "M" defines matrix size.
4. Dimension "N" defines the maximum possible number of pins.
5. Orientation pin is at supplier's option.
6. Controlling dimension: inch.

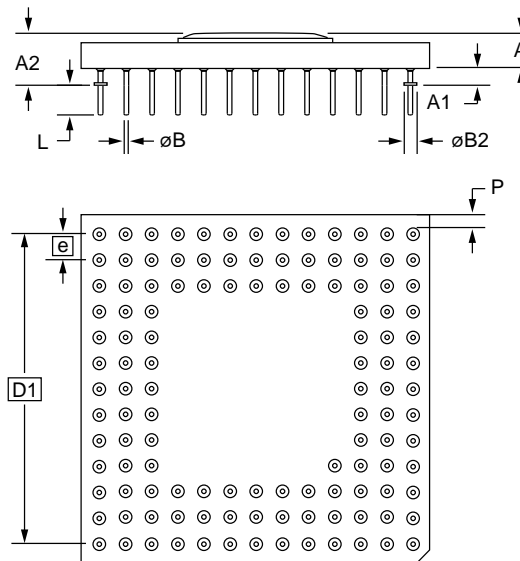
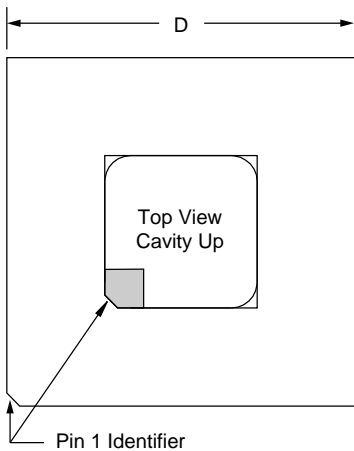

Mechanical Dimensions (continued)

120-Lead MQFP Package

Symbol	Inches		Millimeters		Notes
	Min.	Max.	Min.	Max.	
A	—	.154	—	3.92	
A1	.010	—	.25	—	
A2	.125	.144	3.17	3.67	
B	.012	.018	.30	.45	3, 5
C	.005	.009	.13	.23	5
D/E	1.219	1.238	30.95	31.45	
D1/E1	1.098	1.106	27.90	28.10	
e	.0315 BSC		.80 BSC		
L	.026	.037	.65	.95	4
N	120		120		
ND	30		30		
α	0°	7°	0°	7°	
ccc	—	.004	—	.10	

Notes:

1. All dimensions and tolerances conform to ANSI Y14.5M-1982.
2. Controlling dimension is millimeters.
3. Dimension "B" does not include dambar protrusion. Allowable dambar protrusion shall be .08mm (.003in.) maximum in excess of the "B" dimension. Dambar cannot be located on the lower radius or the foot.
4. "L" is the length of terminal for soldering to a substrate.
5. "B" & "C" includes lead finish thickness.

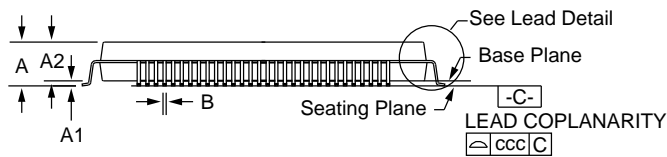
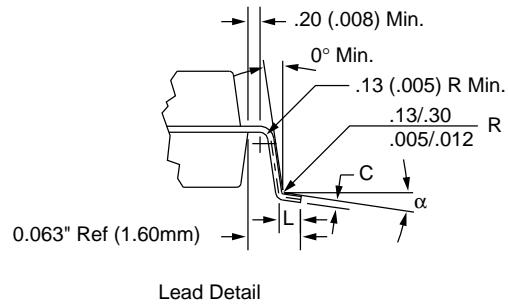
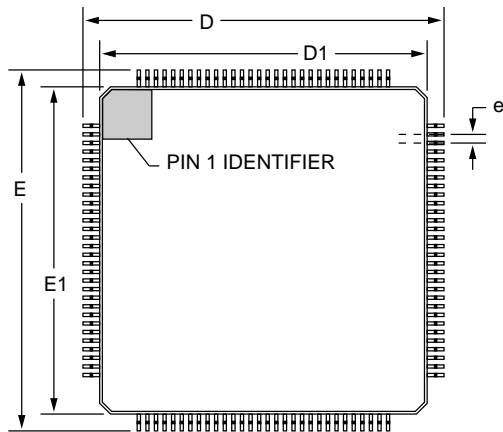

Ordering Information

Product Number	Temperature Range	Speed Grade	Screening	Package	Package Marking
TMC2340AH5C	0° to 70°C	20 MHz	Commercial	121-Pin Plastic Pin Grid Array	2340AH5C
TMC2340AH5C1	0° to 70°C	40 MHz	Commercial	121-Pin Plastic Pin Grid Array	2340AH5C1
TMC2340AH5C2	0° to 70°C	50 MHz	Commercial	121-Pin Plastic Pin Grid Array	2340AH5C2
TMC2340AKEC	0° to 70°C	20 MHz	Commercial	120-Pin Metric Quad FlatPack	2340AKEC
TMC2340AKEC1	0° to 70°C	40 MHz	Commercial	120-Pin Metric Quad FlatPack	2340AKEC1
TMC2340AKEC2	0° to 70°C	50 MHz	Commercial	120-Pin Metric Quad FlatPack	2340AKEC2

The information contained in this data sheet has been carefully compiled; however, it shall not by implication or otherwise become part of the terms and conditions of any subsequent sale. Raytheon's liability shall be determined solely by its standard terms and conditions of sale. No representation as to application or use or that the circuits are either licensed or free from patent infringement is intended or implied. Raytheon reserves the right to change the circuitry and any other data at any time without notice and assumes no liability for errors.

LIFE SUPPORT POLICY:

Raytheon's products are not designed for use in life support applications, wherein a failure or malfunction of the component can reasonably be expected to result in personal injury. The user of Raytheon components in life support applications assumes all risk of such use and indemnifies Raytheon Company against all damages.

Raytheon Electronics
 Semiconductor Division
 5580 Morehouse Drive
 San Diego, CA 92121
 619 457 1000
 800 722 7074
 Fax 619 455 6314
applications@lj.sd.ray.com